

EVALUATION KIT  
AVAILABLE



# Multirate Laser Driver with Extinction Ratio Control

MAX3737

## General Description

The MAX3737 is a +3.3V laser driver designed for multirate transceiver modules with data rates from 155Mbps to 2.7Gbps. Lasers can be DC-coupled to the MAX3737 for reduced component count and ease of multirate operation.

Laser extinction ratio control (ERC) combines the features of automatic power control (APC), modulation compensation, and built-in thermal compensation. The APC loop maintains constant average optical power. Modulation compensation increases the modulation current in proportion to the bias current. These control loops combined with thermal compensation maintain a constant optical extinction ratio over temperature and lifetime.

The MAX3737 accepts differential data input signals. The wide 5mA to 60mA (up to 85mA AC-coupled) modulation current range and up to 100mA bias current range makes the MAX3737 ideal for driving FP/DFB lasers in fiber-optic modules. External resistors set the required laser current levels. The MAX3737 provides transmit disable control (TX\_DISABLE), single-point fault tolerance, bias-current monitoring, modulation-current monitoring, and photocurrent monitoring. The device also offers a latched failure output (TX\_FAULT) to indicate faults, such as when the APC loop is no longer able to maintain the average optical power at the required level. The MAX3737 is compliant with the SFF-8472 transmitter diagnostic and SFP MSA timing requirements.

The MAX3737 is offered in a 5mm x 5mm 32-pin thin QFN and QFN package and operates over the -40°C to +85°C extended temperature range.

## Applications

Multirate OC-3 to OC-48 FEC Transceivers  
Gigabit Ethernet SFF/SFP and GBIC Transceivers  
1Gbps/2Gbps Fibre Channel SFF/SFP and GBIC Transceivers

**Functional Diagram and Typical Application Circuit appear at end of data sheet.**

## Features

- ◆ **Single +3.3V Power Supply**
- ◆ **47mA Power-Supply Current**
- ◆ **85mA Modulation Current**
- ◆ **100mA Bias Current**
- ◆ **Automatic Power Control (APC)**
- ◆ **Modulation Compensation**
- ◆ **On-Chip Temperature Compensation**
- ◆ **Self-Biased Inputs for AC-Coupling**
- ◆ **Ground-Referenced Current Monitors**
- ◆ **Laser Safety, Shutdown, and Alarm Outputs**

## Ordering Information

PART	TEMP RANGE	PIN-PACKAGE
MAX3737ETJ	-40°C to +85°C	32 Thin QFN
MAX3737ETJ+	-40°C to +85°C	32 Thin QFN
MAX3737EGJ	-40°C to +85°C	32 QFN

+ Denotes lead-free packaging.

## Pin Configurations

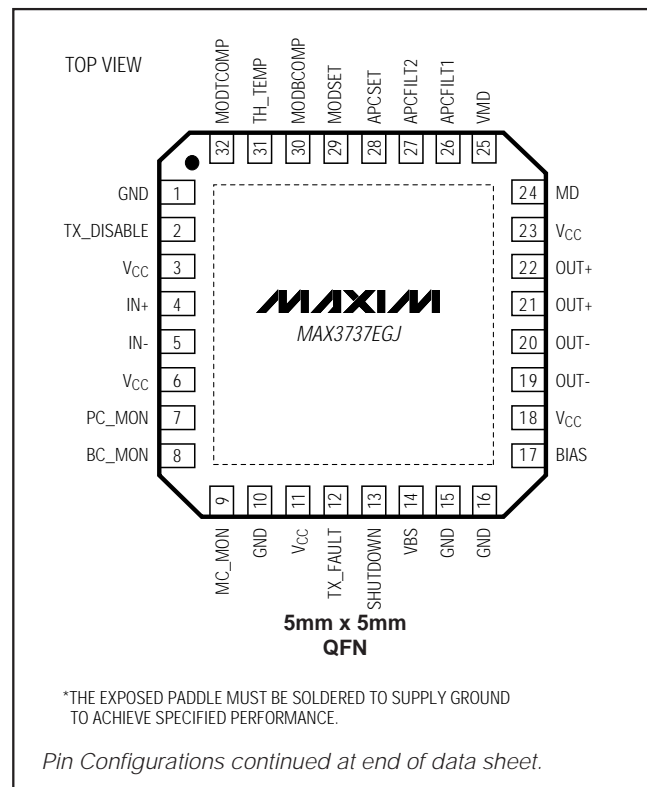

# Multirate Laser Driver with Extinction Ratio Control

## ABSOLUTE MAXIMUM RATINGS

Supply Voltage $V_{CC}$ .....	-0.5V to +6.0V	OUT+, OUT-, BIAS Current.....	-20mA to +150mA
IN+, IN-, TX_DISABLE, TX_FAULT, SHUTDOWN, MC_MON, BC_MON, PC_MON, VBS, VMD, APCFILT1, APCFILT2, MD, TH_TEMP, MODTCOMP, MODBCOMP, MODSET, and APCSET Voltage.....	-0.5V to $V_{CC} + 0.5V$	Continuous Power Dissipation ( $T_A = +85^\circ\text{C}$ ) 32-Pin QFN (derate 21.2mW/ $^\circ\text{C}$ above +85 $^\circ\text{C}$ ) .....	1.3W
		Operating Junction Temperature Range.....	-55 $^\circ\text{C}$ to +150 $^\circ\text{C}$
		Storage Temperature Range.....	-55 $^\circ\text{C}$ to +150 $^\circ\text{C}$

Stresses beyond those listed under "Absolute Maximum Ratings" may cause permanent damage to the device. These are stress ratings only, and functional operation of the device at these or any other conditions beyond those indicated in the operational sections of the specifications is not implied. Exposure to absolute maximum rating conditions for extended periods may affect device reliability.

## ELECTRICAL CHARACTERISTICS

( $V_{CC} = +2.97V$  to  $+3.63V$ ,  $T_A = -40^\circ\text{C}$  to  $+85^\circ\text{C}$ . Typical values are at  $V_{CC} = +3.3V$ ,  $I_{BIAS} = 60\text{mA}$ ,  $I_{MOD} = 60\text{mA}$ ,  $T_A = +25^\circ\text{C}$ , unless otherwise noted.) (Notes 1, 2)

PARAMETER	SYMBOL	CONDITIONS		MIN	TYP	MAX	UNITS
<b>POWER SUPPLY</b>							
Supply Current	$I_{CC}$	(Note 3)			47	60	mA
Power-Supply Noise Rejection	PSNR	$f \leq 1\text{MHz}$ , 100mVp-p (Notes 4, 6)			33		dB
<b>I/O SPECIFICATIONS</b>							
Differential Input Swing	$V_{ID}$	DC-coupled, Figure 1		0.2		2.4	Vp-p
Common-Mode Input	$V_{CM}$			1.7		$V_{CC} - V_{ID}/4$	V
<b>LASER BIAS</b>							
Bias-Current Setting Range				1		100	mA
Bias Off Current		TX_DISABLE = high				0.1	mA
Bias-Current Monitor Ratio		$I_{BIAS}/I_{BC\_MON}$		68	82	95	mA/mA
<b>LASER MODULATION</b>							
Modulation-Current Setting Range	$I_{MOD}$	(Note 5)		5		85	mA
Output Edge Speed		20% to 80% (Notes 6, 7)	$5\text{mA} \leq I_{MOD} \leq 10\text{mA}$		71	80	ps
			$10\text{mA} < I_{MOD} \leq 85\text{mA}$		52	80	
Output Overshoot/Undershoot		(Note 7)			$\pm 6$		%
Random Jitter		(Notes 6, 7)			0.65	1.3	ps
Deterministic Jitter (Notes 6, 8)		2.7Gbps	$5\text{mA} \leq I_{MOD} \leq 10\text{mA}$		25.6	40	psp-p
			$10\text{mA} < I_{MOD} \leq 85\text{mA}$		16	40	
		1.25Gbps	$5\text{mA} \leq I_{MOD} \leq 10\text{mA}$		32	41	
			$10\text{mA} < I_{MOD} \leq 85\text{mA}$		15	41	
		622Mbps	$5\text{mA} \leq I_{MOD} \leq 10\text{mA}$		39	46	
			$10\text{mA} < I_{MOD} \leq 85\text{mA}$		21	46	
155Mbps	$5\text{mA} \leq I_{MOD} \leq 10\text{mA}$		65	100			
	$10\text{mA} < I_{MOD} \leq 85\text{mA}$		46	70			
Modulation-Current Temperature Stability		(Note 6)			$\pm 150$	$\pm 480$	ppm/ $^\circ\text{C}$

# Multirate Laser Driver with Extinction Ratio Control

MAX3737

## ELECTRICAL CHARACTERISTICS (continued)

( $V_{CC} = +2.97V$  to  $+3.63V$ ,  $T_A = -40^{\circ}C$  to  $+85^{\circ}C$ . Typical values are at  $V_{CC} = +3.3V$ ,  $I_{BIAS} = 60mA$ ,  $I_{MOD} = 60mA$ ,  $T_A = +25^{\circ}C$ , unless otherwise noted.) (Notes 1, 2)

PARAMETER	SYMBOL	CONDITIONS	MIN	TYP	MAX	UNITS
Modulation-Current Setting Error		15Ω load, $T_A = +25^{\circ}C$	$5mA \leq I_{MOD} \leq 10mA$		$\pm 20$	%
			$10mA < I_{MOD} \leq 85mA$		$\pm 15$	
Modulation Off Current		$TX\_DISABLE = high$			0.1	mA
Modulation-Current Monitor Ratio		$I_{MOD}/I_{MC\_MON}$	223	262	302	mA/mA
<b>EXTINCTION RATIO CONTROLS</b>						
Monitor-Diode Input Current Range	$I_{MD}$	Average current into the MD pin	18		1500	μA
MD Pin Voltage					1.4	V
MD-Current Monitor Ratio		$I_{MD}/I_{PC\_MON}$	0.85	1.0	1.15	mA/mA
APC Loop Time Constant		$C_{APC\_FILT} = 0.01\mu F$ , $\Delta I_{MD}/\Delta I_{BIAS} = 1/70$		3.3		μs
APC Setting Stability				$\pm 100$	$\pm 480$	ppm/ $^{\circ}C$
APC Setting Accuracy		$T_A = +25^{\circ}C$			$\pm 15$	%
$I_{MOD}$ Compensation Setting Range by Bias	K	$K = \Delta I_{MOD}/\Delta I_{BIAS}$	0		1.5	mA/mA
$I_{MOD}$ Compensation Setting Range by Temperature	TC	$TC = \Delta I_{MOD}/\Delta T$ (Note 6)	0		1.0	mA/ $^{\circ}C$
Threshold Setting Range for Temperature Compensation	$T_{TH}$	(Note 6)	10		60	$^{\circ}C$
<b>LASER SAFETY AND CONTROL</b>						
Bias and Modulation Turn-Off Delay		$C_{APC\_FILT} = 0.01\mu F$ , $\Delta I_{MD}/\Delta I_{BIAS} = 1/80$ (Note 6)			5	μs
Bias and Modulation Turn-On Delay		$C_{APC\_FILT} = 0.01\mu F$ , $\Delta I_{MD}/\Delta I_{BIAS} = 1/80$ (Note 6)			600	μs
Threshold Voltage at Monitor Pins	$V_{REF}$	Figure 5	1.14	1.3	1.39	V
<b>INTERFACE SIGNALS</b>						
$TX\_DISABLE$ Input High	$V_{HI}$		2.0			V
$TX\_DISABLE$ Input Low	$V_{LO}$	$R_{PULL} = 7.5k\Omega$			0.8	V
$TX\_DISABLE$ Input Current		$V_{HI} = V_{CC}$			15	μA
		$V_{LO} = GND$			-450 -800	
$TX\_FAULT$ Output Low		Sinking 1mA, open collector			0.4	V
Shutdown Output High		Sourcing 100μA	$V_{CC} - 0.4$			V
Shutdown Output Low		Sinking 100μA			0.4	V

**Note 1:** AC characterization is performed using the circuit in Figure 2 using a PRBS 2<sup>23</sup> - 1 or equivalent test pattern.

**Note 2:** Specifications at  $-40^{\circ}C$  are guaranteed by design and characterization.

**Note 3:** Excluding  $I_{BIAS}$  and  $I_{MOD}$ . Input data is AC-coupled.  $TX\_FAULT$  open,  $SHUTDOWN$  open.

**Note 4:** Power-supply noise rejection (PSNR) =  $20\log_{10}(V_{noise} (on V_{CC})/\Delta V_{OUT})$ .  $V_{OUT}$  is the voltage across the 15Ω load when  $IN+$  is high.

**Note 5:** The minimum required voltage at the  $OUT+$  and  $OUT-$  pins is  $+0.75V$ .

**Note 6:** Guaranteed by design and characterization.

**Note 7:** Tested with 00001111 pattern at 2.7Gbps.

**Note 8:** DJ includes pulse-width distortion (PWD).

# Multirate Laser Driver with Extinction Ratio Control

## Typical Operating Characteristics

( $V_{CC} = +3.3V$ ,  $C_{APC} = 0.01\mu F$ ,  $I_{BIAS} = 20mA$ ,  $I_{MOD} = 30mA$ ,  $T_A = +25^\circ C$ , unless otherwise noted.)

**OPTICAL EYE DIAGRAM**  
(2.7Gbps, 2<sup>7</sup> - 1PRBS, 2.3GHz FILTER)

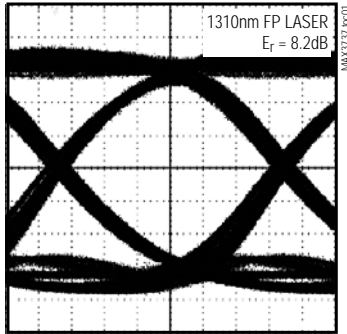

54ps/div

**OPTICAL EYE DIAGRAM**  
(1.25Gbps, 2<sup>7</sup> - 1PRBS, 940MHz FILTER)

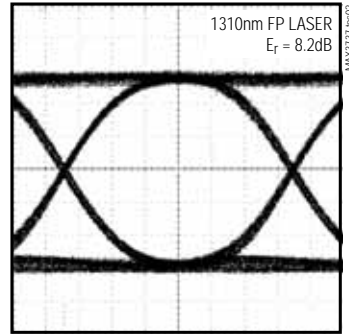

116ps/div

**OPTICAL EYE DIAGRAM**  
(155Mbps, 2<sup>7</sup> - 1PRBS, 117MHz FILTER,  $C_{APC} = 0.1\mu F$ )

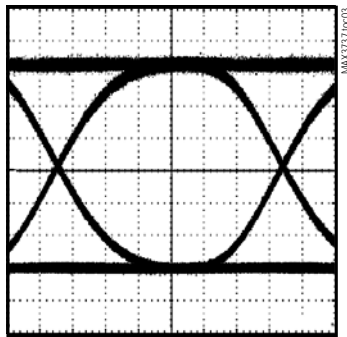

920ps/div

**ELECTRICAL EYE DIAGRAM**  
( $I_{MOD} = 30mA$ , 2.7Gbps, 2<sup>7</sup> - 1PRBS)

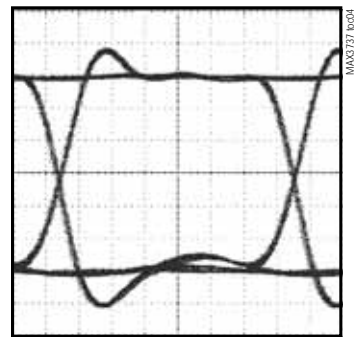

75mV/div

52ps/div

**SUPPLY CURRENT ( $I_{CC}$ ) vs. TEMPERATURE**  
(EXCLUDES BIAS AND MODULATION CURRENTS)

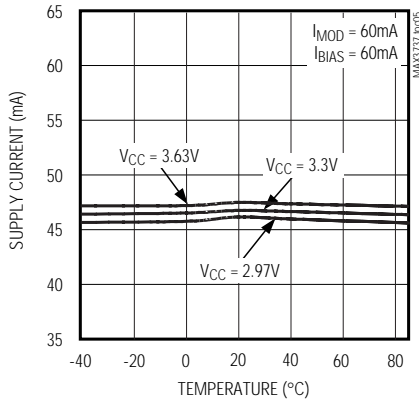

**BIAS-CURRENT MONITOR GAIN vs. TEMPERATURE**

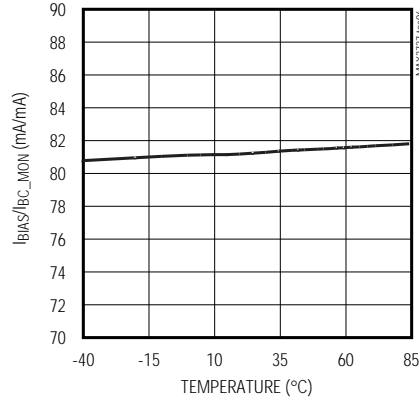

**PHOTO-CURRENT MONITOR GAIN vs. TEMPERATURE**

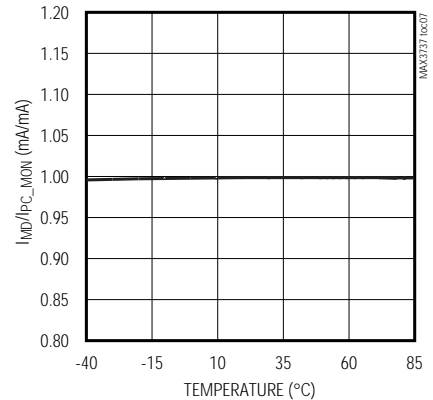

# Multirate Laser Driver with Extinction Ratio Control

MAX3737

## Typical Operating Characteristics (continued)

( $V_{CC} = +3.3V$ ,  $C_{APC} = 0.01\mu F$ ,  $I_{BIAS} = 20mA$ ,  $I_{MOD} = 30mA$ ,  $T_A = +25^\circ C$ , unless otherwise noted.)

**MODULATION-CURRENT MONITOR GAIN vs. TEMPERATURE**

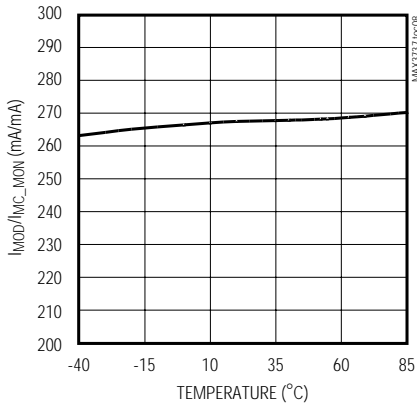

**MODULATION CURRENT vs. R\_MODSET**

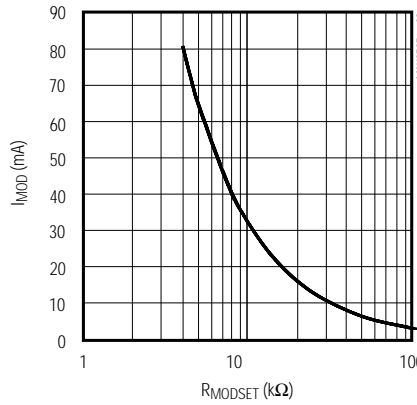

**PHOTODIODE CURRENT vs. R\_PCSET**

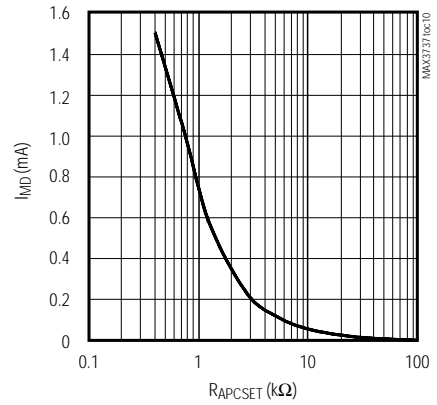

**DETERMINISTIC JITTER vs. MODULATION CURRENT**

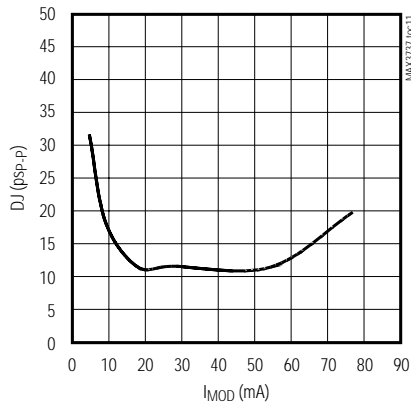

**RANDOM JITTER vs. MODULATION CURRENT**

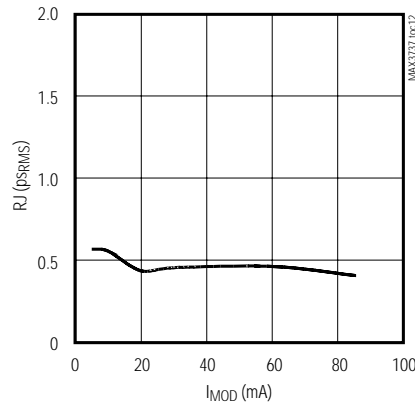

**COMPENSATION (K) vs. R\_MODBCOMP**

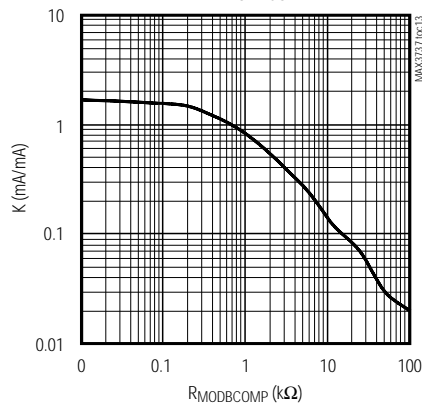

**TEMPERATURE COMPENSATION vs. R\_TH\_TEMP (R\_MODTCOMP = 500Ω)**

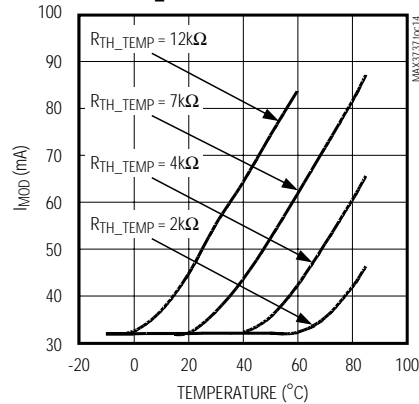

# Multirate Laser Driver with Extinction Ratio Control

## Typical Operating Characteristics (continued)

(V<sub>CC</sub> = +3.3V, C<sub>APC</sub> = 0.01μF, I<sub>BIAS</sub> = 20mA, I<sub>MOD</sub> = 30mA, T<sub>A</sub> = +25°C, unless otherwise noted.)

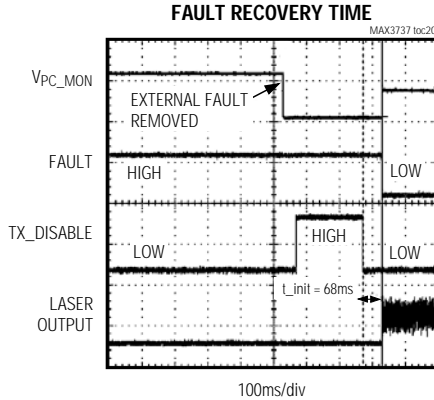
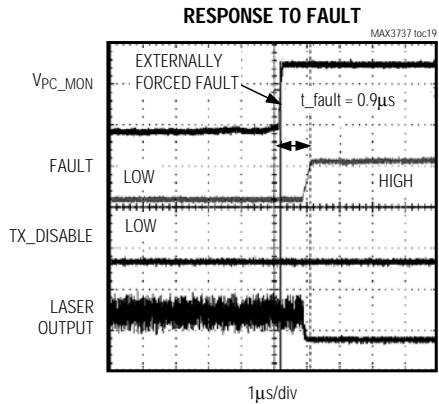
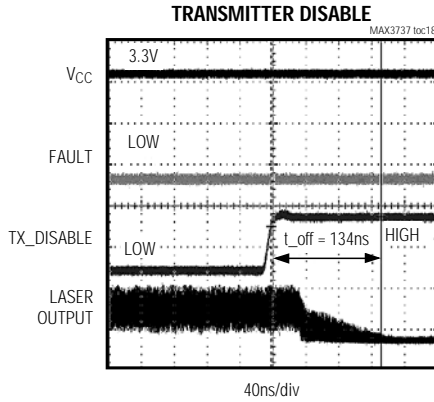
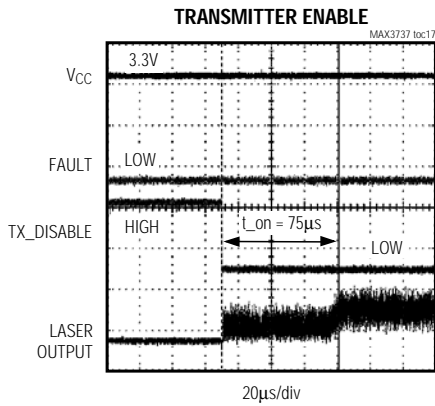
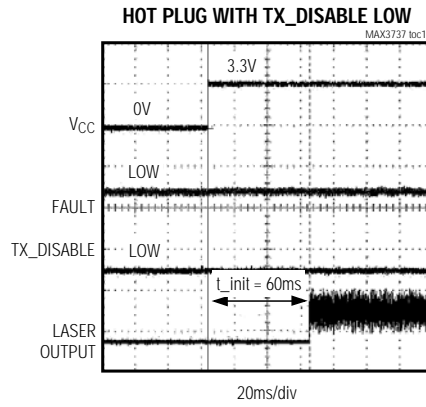
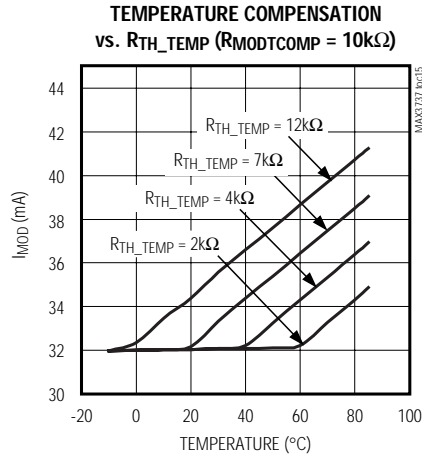

# Multirate Laser Driver with Extinction Ratio Control

## Pin Description

MAX3737

PIN	NAME	FUNCTION
1, 10, 15, 16	GND	Ground
2	TX_DISABLE	Transmitter Disable, TTL. Laser output is disabled when TX_DISABLE is asserted high or left unconnected. The laser output is enabled when this pin is asserted low.
3, 6, 11, 18, 23	V <sub>CC</sub>	+3.3V Supply Voltage
4	IN+	Noninverted Data Input
5	IN-	Inverted Data Input
7	PC_MON	Photodiode-Current Monitor Output. Current out of this pin develops a ground-referenced voltage across an external resistor that is proportional to the monitor-diode current.
8	BC_MON	Bias-Current Monitor Output. Current out of this pin develops a ground-referenced voltage across an external resistor that is proportional to the bias current.
9	MC_MON	Modulation-Current Monitor Output. Current out of this pin develops a ground-referenced voltage across an external resistor that is proportional to the modulation current amplitude.
12	TX_FAULT	Open-Collector Transmit Fault Indicator (Table 1)
13	SHUTDOWN	Shutdown Driver Output. Voltage output to control an external transistor for optional shutdown circuitry.
14	VBS	Bias Voltage Sense. Isolated tap ( $3k\Omega \pm 15\%$ ) on the bias output reduces component count when a precision bias sense resistor is used.
17	BIAS	Laser Bias-Current Output
19, 20	OUT-	Inverted Modulation-Current Output (Connect Pins 19 and 20 Together). I <sub>MOD</sub> flows into this pin when input data is low.
21, 22	OUT+	Noninverted Modulation-Current Output (Connect Pins 21 and 22 Together). I <sub>MOD</sub> flows into this pin when input data is high.
24	MD	Monitor Photodiode Input. Connect this pin to the anode of a monitor photodiode. A capacitor to ground is required to filter the high-speed AC monitor photocurrent.
25	VMD	Monitor Photodiode Voltage Sense. Isolated tap ( $3k\Omega \pm 15\%$ ) on the MD input reduces component count when a precision photodiode current-sense resistor is used.
26	APCFILT1	Connect a capacitor (C <sub>APC</sub> ) between pin 26 (APCFILT1) and pin 27 (APCFILT2) to set the dominant pole of the APC feedback loop.
27	APCFILT2	(See Pin 26.)
28	APCSET	A resistor connected from this pin to ground sets the desired average optical power.
29	MODSET	A resistor connected from this pin to ground sets the desired constant portion of the modulation current.
30	MODBCOMP	Modulation-Current Compensation from Bias. Couples the bias current to the modulation current. Mirrors I <sub>BIAS</sub> through an external resistor. Leave open for zero coupling.
31	TH_TEMP	Threshold for Temperature Compensation. A resistor at this pin programs the temperature, above which compensation is added to the modulation current.
32	MODTCOMP	Modulation-Current Compensation from Temperature. A resistor at this pin sets the temperature coefficient of the modulation current when above the threshold temperature. Leave open for zero temperature compensation.
EP	Exposed Pad	Ground. Solder the exposed pad to the circuit board ground for specified thermal and electrical performance.

# Multirate Laser Driver with Extinction Ratio Control

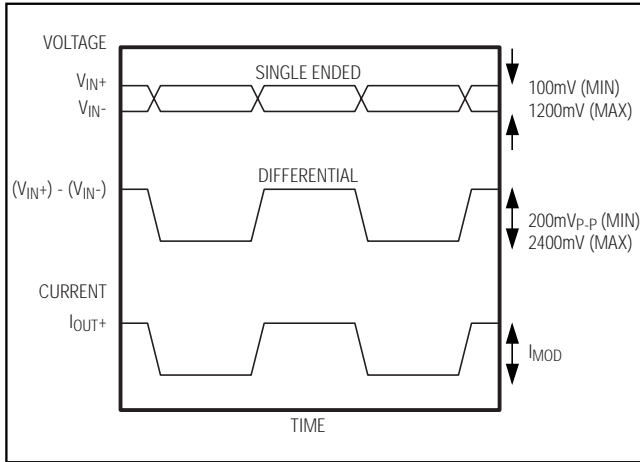

Figure 1. Required Input Signal and Output Polarity

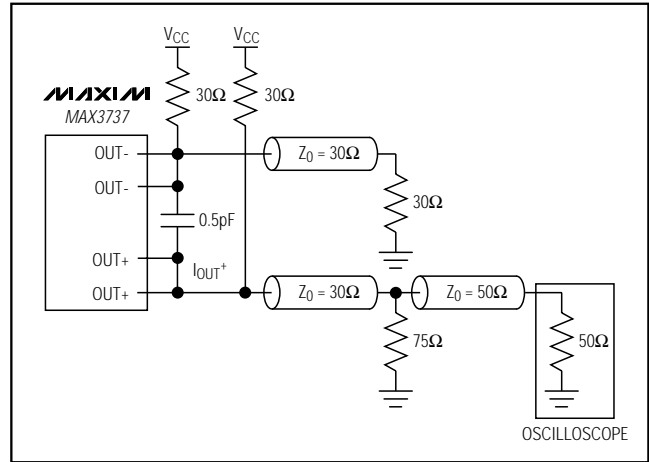

Figure 2. Test Circuit for Characterization

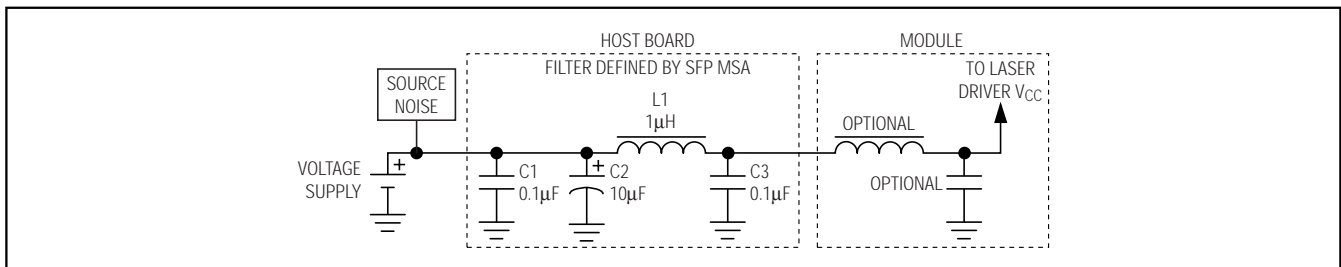

Figure 3. Supply Filter

## Detailed Description

The MAX3737 laser driver consists of three main parts: a high-speed modulation driver, biasing block with ERC, and safety circuitry. The circuit design is optimized for high-speed, low-voltage (+3.3V) operation (Figure 4).

### High-Speed Modulation Driver

The output stage is composed of a high-speed differential pair and a programmable modulation current source. The MAX3737 is optimized for driving a 15Ω load. The minimum instantaneous voltage required at OUT+ is 0.7V for modulation current up to 60mA and 0.75V for currents from 60mA to 85mA. Operation above 60mA can be accomplished by AC-coupling or with sufficient voltage at the laser to meet the driver output voltage requirement.

To interface with the laser diode, a damping resistor (R<sub>D</sub>) is required. The combined resistance due to the series damping resistor and the equivalent series resistance (ESR) of the laser diode should equal 15Ω. To further damp aberrations caused by laser diode parasitic inductance, an RC shunt network may be necessary. Refer to Maxim Application Note HFAN 02.0: *Interfacing Maxim's Laser Drivers to Laser Diodes* for more information.

At data rates of 2.7Gbps, any capacitive load at the cathode of a laser diode degrades optical output performance. Because the BIAS output is directly connected to the laser cathode, minimize the parasitic capacitance associated with the pin by using an inductor to isolate the BIAS pin parasitics from the laser cathode.

### Extinction Ratio Control

The extinction ratio (r<sub>e</sub>) is the laser on-state power divided by the off-state power. Extinction ratio remains constant if peak-to-peak and average power are held constant:

$$r_e = (2P_{AVG} + P_{P-P}) / (2P_{AVG} - P_{P-P})$$

Average power is regulated using APC, which keeps constant current from a photodiode coupled to the laser. Peak-to-peak power is maintained by compensating the modulation current for reduced slope efficiency (η) of the laser over time and temperature:

$$P_{AVG} = \frac{I_{MD}}{P_{MON}}$$

$$P_{P-P} = \eta \times I_{MOD}$$



# Multirate Laser Driver with Extinction Ratio Control

MAX3737

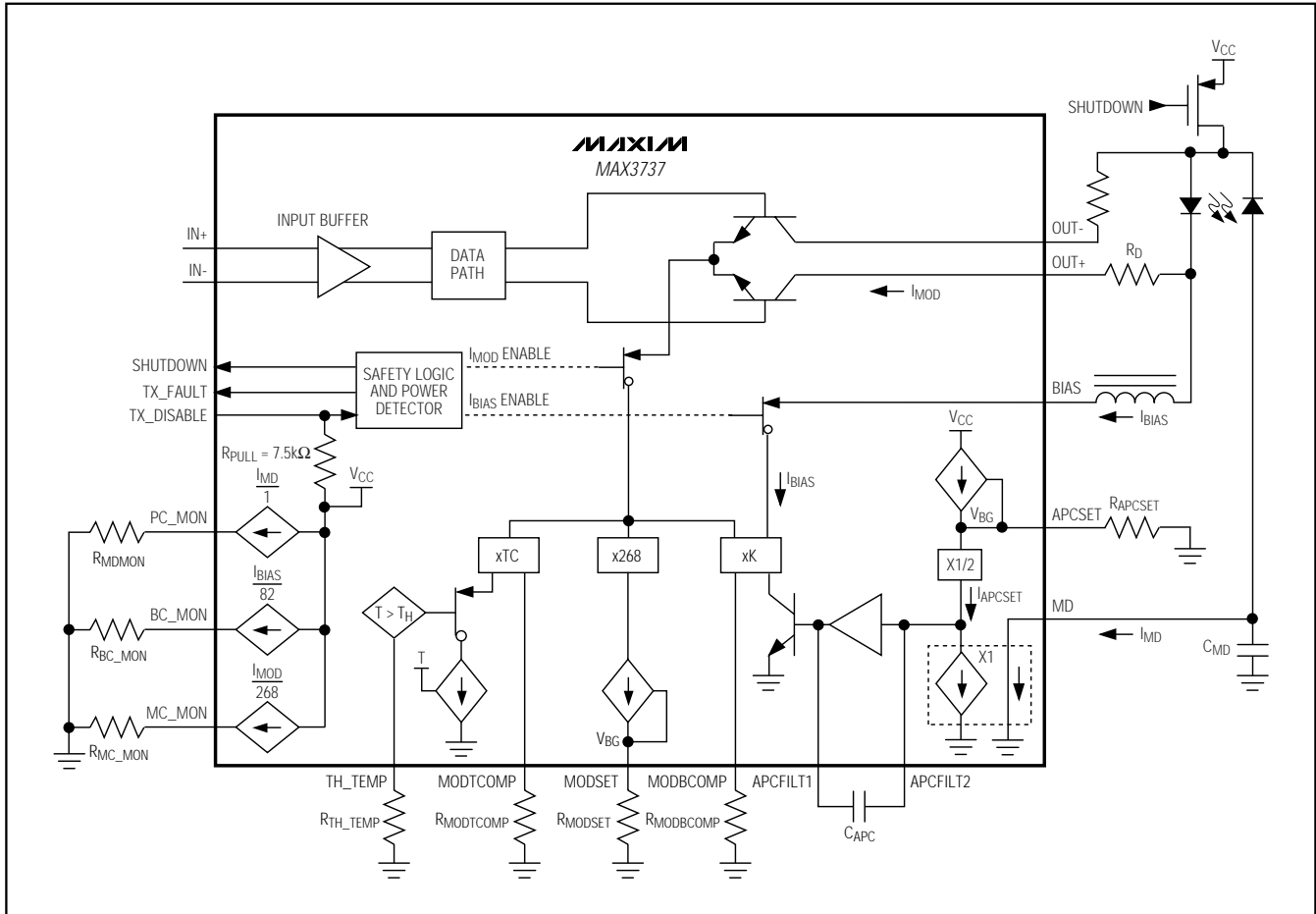

Figure 4. Functional Diagram

Modulation compensation from bias increases the modulation current by a user-selected proportion (K) needed to maintain peak-to-peak laser power as bias current increases with temperature. Refer to Maxim Application Note HFAN-02.2.1 for details:

$$K = \frac{\Delta I_{MOD}}{\Delta I_{BIAS}}$$

This provides a first-order approximation of the current increase needed to maintain peak-to-peak power. Slope efficiency decreases more rapidly as temperature increases. The MAX3737 provides additional temperature compensation as temperature increases past a user-defined threshold ( $T_{TH}$ ).

## Safety Circuitry

The safety circuitry contains a disable, input (TX\_DISABLE), a latched fault output (TX\_FAULT), and fault detectors (Figure 5). This circuitry monitors the operation of the laser driver and forces a shutdown if a fault is detected (Table 1). The TX\_FAULT pin should be pulled high with a 4.7kΩ to 10kΩ resistor to VCC as required by the SFP MSA. A single-point fault can be a short to VCC or GND. See Table 2 to view the circuit response to various single-point failures. The transmit fault condition is latched until reset by a toggle of TX\_DISABLE or VCC. The laser driver offers redundant laser diode shutdown through the optional shutdown circuitry as shown in the *Typical Operating Circuit*. This shutdown transistor prevents a single-point fault at the laser from creating an unsafe condition.

# Multirate Laser Driver with Extinction Ratio Control

**Table 1. Typical Fault Conditions**

1	If any of the I/O pins is shorted to GND or V <sub>CC</sub> (single-point failure; see Table 2), and the bias current or the photocurrent exceed the programmed threshold.
2	End-of-life (EOL) condition of the laser diode. The bias current and/or the photocurrent exceed the programmed threshold.
3	Laser cathode is grounded and photocurrent exceeds the programming threshold.
4	No feedback for the APC loop (broken interconnection, defective monitor photodiode), and the bias current exceeds the programmed threshold.

**Table 2. Circuit Responses to Various Single-Point Faults**

PIN	CIRCUIT RESPONSE TO OVERVOLTAGE OR SHORT TO V <sub>CC</sub>	CIRCUIT RESPONSE TO UNDERVOLTAGE OR SHORT TO GROUND
TX_FAULT	Does not affect laser power.	Does not effect laser power.
TX_DISABLE	Modulation and bias currents are disabled.	Normal condition for circuit operation.
IN+	The optical average power increases and a fault occurs if V <sub>PC_MON</sub> exceeds the threshold. The APC loop responds by decreasing the bias current.	The optical average power decreases and the APC loop responds by increasing the bias current. A fault state occurs if V <sub>BC_MON</sub> exceeds the threshold voltage.
IN-	The optical average power decreases and the APC loop responds by increasing the bias current. A fault state occurs if V <sub>BC_MON</sub> exceeds the threshold voltage.	The optical average power increases and a fault occurs if V <sub>PC_MON</sub> exceeds the threshold. The APC loop responds by decreasing the bias current.
MD	This disables bias current. A fault state occurs.	The APC circuit responds by increasing bias current until a fault is detected, then a fault* state occurs.
SHUTDOWN	Does not affect laser power. If the shutdown circuitry is used, laser current is disabled.	Does not affect laser power.
BIAS	In this condition, laser forward voltage is 0V and no light is emitted.	Fault state* occurs. If the shutdown circuitry is used, laser current is disabled.
OUT+	The APC circuit responds by increasing the bias current until a fault is detected, then a fault state* occurs.	Fault state* occurs. If the shutdown circuitry is used, laser current is disabled.
OUT-	Does not affect laser power.	Does not affect laser power.
PC_MON	Fault state* occurs.	Does not affect laser power.
BC_MON	Fault state* occurs.	Does not affect laser power.
MC_MON	Fault state* occurs.	Does not affect laser power.
APCFILT1	I <sub>BIAS</sub> increases until V <sub>BC_MON</sub> exceeds the threshold voltage.	I <sub>BIAS</sub> increases until V <sub>BC_MON</sub> exceeds the threshold voltage.
APCFILT2	I <sub>BIAS</sub> increases until V <sub>BC_MON</sub> exceeds the threshold voltage.	I <sub>BIAS</sub> increases until V <sub>BC_MON</sub> exceeds the threshold voltage.
MODSET	Does not affect laser power.	Fault state* occurs.
APCSET	Does not affect laser power.	Fault state* occurs.

\*A fault state asserts the TX\_FAULT pin, disables the modulation and bias currents, and asserts the SHUTDOWN pin.

### Safety Circuitry Current Monitors

The MAX3737 features monitors (MC\_MON, BC\_MON, PC\_MON) for modulation current (I<sub>MOD</sub>), bias current (I<sub>BIAS</sub>), and photocurrent (I<sub>MD</sub>). The monitors are realized

by mirroring a fraction of the currents and developing voltages across external resistors connected to ground. Voltages greater than V<sub>REF</sub> at MC\_MON, PC\_MON, or BC\_MON result in a fault state. For example, connecting a

# Multirate Laser Driver with Extinction Ratio Control

100Ω resistor to ground at each monitor output gives the following relationships:

$$V_{MC\_MON} = (I_{MOD} / 268) \times 100\Omega$$

$$V_{BC\_MON} = (I_{BIAS} / 82) \times 100\Omega$$

$$V_{PC\_MON} = I_{MD} \times 100\Omega$$

External sense resistors can be used for high-accuracy measurement of bias and photodiode currents. On-chip isolation resistors are included to reduce the number of components needed to implement this function.

## Design Procedure

When designing a laser transmitter, the optical output is usually expressed in terms of average power and extinction ratio. Table 3 gives relationships that are helpful in converting between the optical average power and the modulation current. These relationships are valid if the mark density and duty cycle of the optical waveform are 50%.

For a desired laser average optical power ( $P_{AVG}$ ) and optical extinction ratio ( $r_e$ ), the required bias and modulation currents can be calculated using the equations in Table 3. Proper setting of these currents requires knowledge of the laser to monitor transfer ( $\rho_{MON}$ ) and slope efficiency ( $\eta$ ).

### Programming the Monitor Diode Current Set Point

The MAX3737 operates in APC mode at all times. The bias current is automatically set so average laser power is determined by the APCSET resistor:

$$P_{AVG} = \frac{I_{MD}}{\rho_{MON}}$$

The APCSET pin controls the set point for the monitor-diode current. An internal current regulator establishes the APCSET current in the same manner as the MODSET pin. See the  $I_{MD}$  vs.  $R_{APCSET}$  graph in the *Typical Operating Characteristics* and select the value of  $R_{APCSET}$  that corresponds to the required current at +25°C:

$$I_{MD} = \frac{1}{2} \times \frac{V_{REF}}{R_{APCSET}}$$

The laser driver automatically adjusts the bias to maintain the constant average power. For DC-coupled laser diodes:

$$I_{AVG} = I_{BIAS} + \frac{I_{MOD}}{2}$$

### Programming the Modulation Current with Compensation

Determine the modulation current from the laser slope efficiency:

$$I_{MOD} = 2 \times \frac{P_{AVG}}{\eta} \times \frac{r_e - 1}{r_e + 1}$$

The modulation current of the MAX3737 consists of a static modulation current ( $I_{MODS}$ ), a current proportional to  $I_{BIAS}$ , and a current proportional to temperature. The portion of  $I_{MOD}$  set by MODSET is established by an internal current regulator, which maintains the reference voltage of  $V_{REF}$  across the external programming resistor. See to the  $I_{MOD}$  vs.  $R_{MODSET}$  graph in the *Typical Operating Characteristics* and select the value of  $R_{MODSET}$  that corresponds to the required current at +25°C:

**Table 3. Optical Power Relations**

PARAMETER	SYMBOL	RELATION
Average power	$P_{AVG}$	$P_{AVG} = (P_0 + P_1) / 2$
Extinction ratio	$r_e$	$r_e = P_1 / P_0$
Optical power of a 1	$P_1$	$P_1 = 2P_{AVG} r_e / (r_e + 1)$
Optical power of a zero	$P_0$	$P_0 = 2P_{AVG} / (r_e + 1)$
Optical amplitude	$P_{P-P}$	$P_{P-P} = P_1 - P_0$
Laser slope efficiency	$\eta$	$\eta = P_{P-P} / I_{MOD}$
Modulation current	$I_{MOD}$	$I_{MOD} = P_{P-P} / \eta$
Threshold current	$I_{TH}$	$P_0$ at $I \geq I_{TH}$
Bias current (AC-coupled)	$I_{BIAS}$	$I_{BIAS} \geq I_{TH} + I_{MOD} / 2$
Laser to monitor transfer	$\rho_{MON}$	$I_{MD} / P_{AVG}$

**Note:** Assuming a 50% average input duty cycle and mark density.

# Multirate Laser Driver with Extinction Ratio Control

$$I_{MOD} = I_{MODS} + K \times I_{BIAS} + I_{MODT}$$

$$I_{MODS} = 268 \times \frac{V_{REF}}{R_{MODSET}}$$

$$I_{MODT} = TC \times (T - T_{TH}) \quad | \quad T > T_{TH}$$

$$I_{MODT} = 0 \quad | \quad T \leq T_{TH}$$

An external resistor at the MODBCOMP pin sets current proportional to  $I_{BIAS}$ . Open circuiting the MODBCOMP pin can turn off the interaction between  $I_{BIAS}$  and  $I_{MOD}$ :

$$K = \frac{1700}{1000 + R_{MODBCOMP}} \pm 10\%$$

If  $I_{MOD}$  must be increased from  $I_{MOD1}$  to  $I_{MOD2}$  to maintain the extinction ratio at elevated temperature, the required compensation factor is:

$$K = \frac{I_{MOD2} - I_{MOD1}}{I_{BIAS2} - I_{BIAS1}}$$

A threshold for additional temperature compensation can be set with a programming resistor at the TH\_TEMP pin:

$$T_{TH} = -70^{\circ}\text{C} + \frac{1.45\text{M}\Omega}{9.2\text{k}\Omega + R_{TH\_TEMP}}^{\circ}\text{C} \pm 10\%$$

The temperature coefficient of thermal compensation above  $T_{TH}$  is set by  $R_{MODTCOMP}$ . Leaving the MODT-COMP pin open disables additional thermal compensation:

$$TC = \frac{1}{0.5 + R_{MODTCOMP}(\text{k}\Omega)} \frac{\text{mA}}{^{\circ}\text{C}} \pm 10\%$$

## Current Compliance ( $I_{MOD} \leq 60\text{mA}$ ), DC-Coupled

The minimum voltage at the OUT+ and OUT- pins is 0.7V.

For:

$V_{DIODE}$ —Diode bias point voltage (1.2V typ)

$R_L$ —Diode bias point resistance (5 $\Omega$  typ)

$R_D$ —Series matching resistor (20 $\Omega$  typ)

For compliance:

$$V_{OUT+} = V_{CC} - V_{DIODE} - I_{MOD} \times (R_D + R_L) - I_{BIAS} \times R_L \geq 0.7\text{V}$$

## Current Compliance ( $I_{MOD} > 60\text{mA}$ ), AC-Coupled

For applications requiring modulation current greater than 60mA, headroom is insufficient for proper operation of the laser driver if the laser is DC-coupled. To avoid this problem, the MAX3737's modulation output can be AC-coupled to the cathode of a laser diode. An external pullup inductor is necessary to DC-bias the modulation output at  $V_{CC}$ . Such a configuration isolates laser forward voltage from the output circuitry and allows the output at OUT+ to swing above and below the supply voltage ( $V_{CC}$ ). When AC-coupled, the MAX3737 modulation current can be programmed up to 85mA. Refer to Maxim Application Note HFAN 02.0: *Interfacing Maxim's Laser Drivers to Laser Diodes* for more information on AC-coupling laser drivers to laser diodes.

For compliance:

$$V_{OUT+} = V_{CC} - \frac{I_{MOD}}{2} \times (R_D + R_L) \geq 0.75\text{V}$$

## Determine $C_{APC}$

The APC loop filter capacitor  $C_{APC}$  must be selected to balance the requirements for fast turn-on and minimal interaction with low frequencies in the data pattern. The low-frequency cutoff is:

$$C_{APC}(\mu\text{F}) \approx \frac{68}{f_{3DB}(\text{KHZ})} \times (\eta \times \rho_{MON})^{1.1}$$

High-frequency noise can be filtered with an additional cap  $C_{MD}$  from the MD pin to ground:

$$C_{MD} \approx \frac{C_{APC}}{4}$$

The MAX3737 is designed so that turn-on time is faster than 1ms for most laser gain values ( $\eta \times \rho_{MON}$ ). Choosing a smaller value of  $C_{APC}$  reduces turn-on time. Careful balance between turn-on time and low-frequency cutoff may be needed at low data rates for some values of laser gain.

## Interface Models

Figures 6 and 7 show simplified input and output circuits for the MAX3737 laser driver. If dice are used, replace package parasitic elements with bondwire parasitic elements.

# Multirate Laser Driver with Extinction Ratio Control

MAX3737

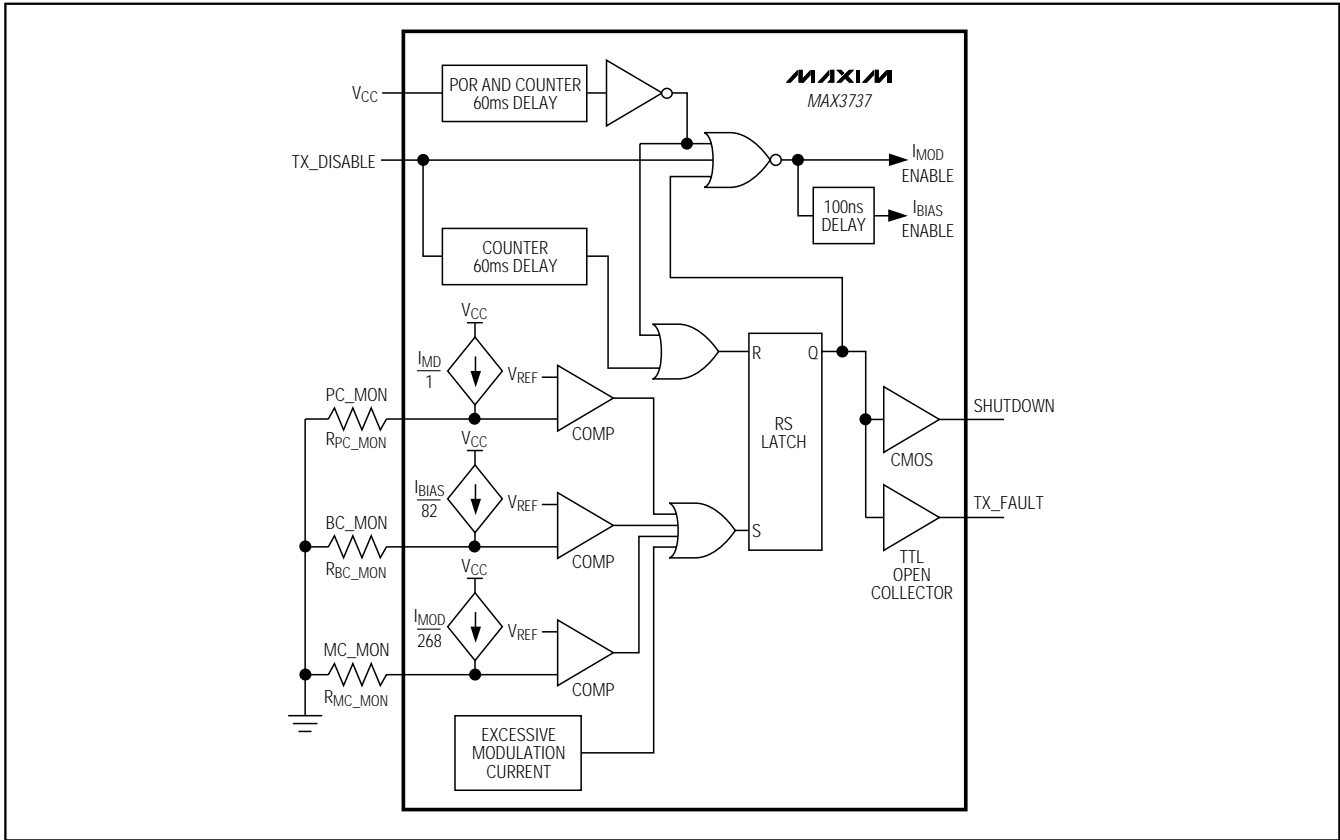

Figure 5. Simplified Safety Circuit

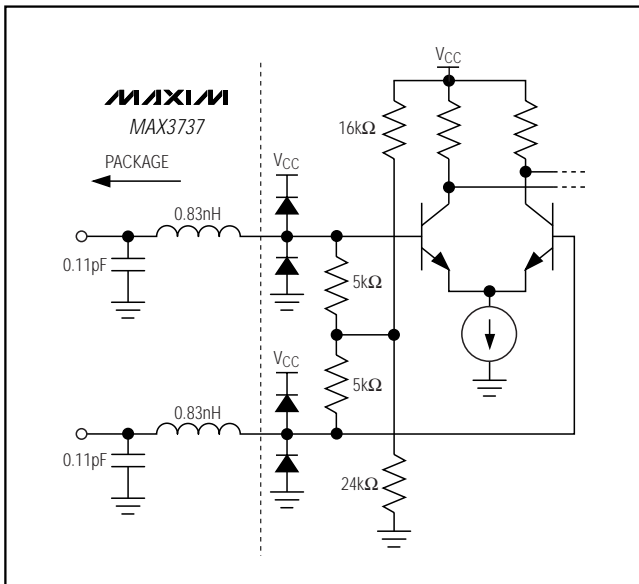

Figure 6. Simplified Input Structure

## Layout Considerations

To minimize loss and crosstalk, keep the connections between the MAX3737 output and the laser diode as short as possible. Use good high-frequency layout techniques and multilayer boards with uninterrupted ground plane to minimize EMI and crosstalk. Circuit boards should be made using low-loss dielectrics. Use controlled-impedance lines for data inputs, as well as the module output.

## Laser Safety and IEC 825

Using the MAX3737 laser driver alone does not ensure that a transmitter design is IEC 825 compliant. The entire transmitter circuit and component selections must be considered. Each customer must determine the level of fault tolerance required by their application, recognizing that Maxim products are not designed or authorized for use as components in systems intended for surgical implant into the body, for applications intended to support or sustain life, or for any other application where the failure of a Maxim product could create a situation where personal injury or death may occur.

# Multirate Laser Driver with Extinction Ratio Control

## Exposed-Pad (EP) Package

The exposed-pad on the 32-pin QFN provides a very low thermal resistance path for heat removal from the IC. The pad is also electrical ground on the MAX3737 and should be soldered to the circuit board ground for proper thermal and electrical performance. Refer to Maxim Application Note HFAN-08.1: *Thermal Considerations for QFN and Other Exposed Pad Packages* at [www.maxim-ic.com](http://www.maxim-ic.com) for additional information.

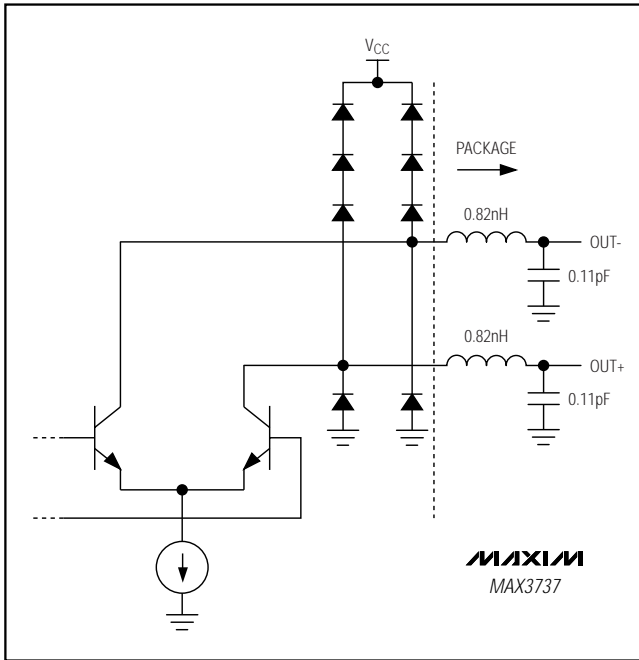
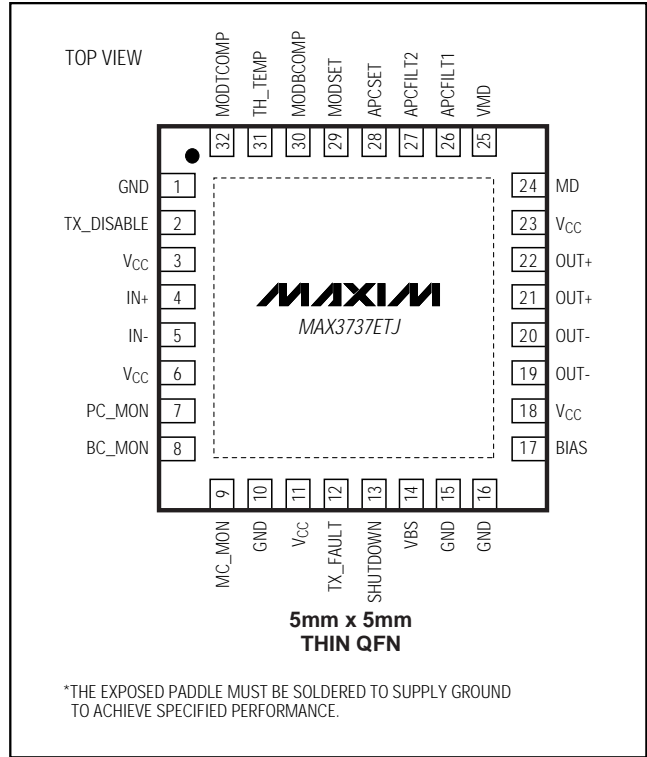

Figure 7. Simplified Output Structure

## Pin Configurations (continued)



## Chip Information

TRANSISTOR COUNT: 2727

PROCESS: SiGe/Bipolar



# Multirate Laser Driver with Extinction Ratio Control

## Package Information

(The package drawing(s) in this data sheet may not reflect the most current specifications. For the latest package outline information, go to [www.maxim-ic.com/packages](http://www.maxim-ic.com/packages).)

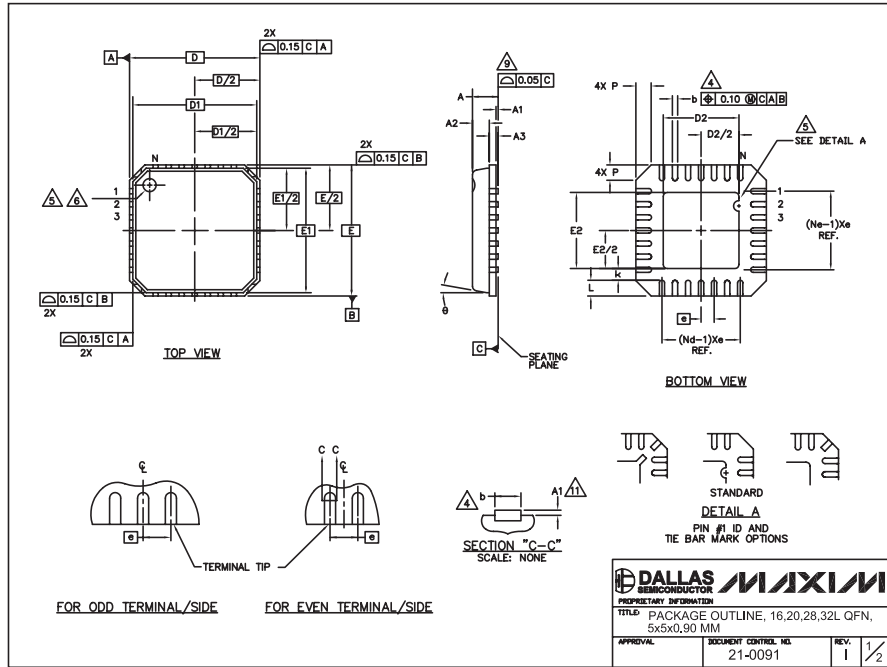

COMMON DIMENSIONS												
PKG SYMBOL	16L 5x5			20L 5x5			28L 5x5			32L 5x5		
	MIN.	NOM.	MAX.	MIN.	NOM.	MAX.	MIN.	NOM.	MAX.	MIN.	NOM.	MAX.
A	0.80	0.90	1.00	0.80	0.90	1.00	0.80	0.90	1.00	0.80	0.90	1.00
A1	0.00	0.01	0.05	0.00	0.01	0.05	0.00	0.01	0.05	0.00	0.01	0.05
A2	0.00	0.65	1.00	0.00	0.65	1.00	0.00	0.65	1.00	0.00	0.65	1.00
A3	0.20 REF			0.20 REF			0.20 REF			0.20 REF		
b	0.28	0.33	0.40	0.23	0.28	0.35	0.18	0.23	0.30	0.18	0.23	0.30
D	4.90	5.00	5.10	4.90	5.00	5.10	4.90	5.00	5.10	4.90	5.00	5.10
D1	4.75 BSC			4.75 BSC			4.75 BSC			4.75 BSC		
E	4.90	5.00	5.10	4.90	5.00	5.10	4.90	5.00	5.10	4.90	5.00	5.10
E1	4.75 BSC			4.75 BSC			4.75 BSC			4.75 BSC		
e	0.80 BSC			0.65 BSC			0.50 BSC			0.50 BSC		
k	0.25	-	-	0.25	-	-	0.25	-	-	0.25	-	-
L	0.35	0.55	0.75	0.35	0.55	0.75	0.35	0.55	0.75	0.30	0.40	0.50
N	16			20			28			32		
ND	4			5			7			8		
NE	4			5			7			8		
P	0.00	0.42	0.60	0.00	0.42	0.60	0.00	0.42	0.60	0.00	0.42	0.60
e	0"			12"			0"			12"		

EXPOSED PAD VARIATIONS						
PKG CODES	D2			E2		
	MIN.	NOM.	MAX.	MIN.	NOM.	MAX.
G1655-3	2.95	3.10	3.25	2.95	3.10	3.25
G2055-1	2.55	2.70	2.85	2.55	2.70	2.85
G2055-2	2.95	3.10	3.25	2.95	3.10	3.25
G2855-1	2.55	2.70	2.85	2.55	2.70	2.85
G2855-2	2.95	3.10	3.25	2.95	3.10	3.25
G3255-1	2.95	3.10	3.25	2.95	3.10	3.25

NOTES:

- DIE THICKNESS ALLOWABLE IS 0.305mm MAXIMUM (.012 INCHES MAXIMUM)
- DIMENSIONING & TOLERANCES CONFORM TO ASME Y14.5M, - 1994.
- N IS THE NUMBER OF TERMINALS.
- Nd IS THE NUMBER OF TERMINALS IN X-DIRECTION & Ne IS THE NUMBER OF TERMINALS IN Y-DIRECTION.
- △ DIMENSION b APPLIES TO PLATED TERMINAL AND IS MEASURED BETWEEN 0.20 AND 0.25mm FROM TERMINAL TIP.
- △ THE PIN #1 IDENTIFIER MUST BE EXISTED ON THE TOP SURFACE OF THE PACKAGE BY USING INDENTATION MARK OR INK/LASER MARKED. DETAILS OF PIN #1 IDENTIFIER IS OPTIONAL, BUT MUST BE LOCATED WITHIN ZONE INDICATED.
- △ EXACT SHAPE AND SIZE OF THIS FEATURE IS OPTIONAL.
- ALL DIMENSIONS ARE IN MILLIMETERS.
- PACKAGE WARPAGE MAX 0.05mm.
- △ APPLIED FOR EXPOSED PAD AND TERMINALS. EXCLUDE EMBEDDED PART OF EXPOSED PAD FROM MEASURING.
- MEETS JEDEC MO220; EXCEPT DIMENSION "b".
- △ APPLIED FOR EXPOSED PAD AND TERMINALS. EXCLUDE EMBEDDING PART OF EXPOSED PAD FROM MEASURING.
- THIS PACKAGE OUTLINE APPLIES TO ANVIL SINGULATION (STEPPED SIDES).

DALLAS SEMICONDUCTOR MAXIM

PROPRIETARY INFORMATION

TITLE: PACKAGE OUTLINE, 16,20,28,32L QFN, 5x5x0,90 MM

APPROVAL:      DOCUMENT CONTROL: 21-0091      REV: 1/2



# Multirate Laser Driver with Extinction Ratio Control

## Package Information (continued)

(The package drawing(s) in this data sheet may not reflect the most current specifications. For the latest package outline information, go to [www.maxim-ic.com/packages](http://www.maxim-ic.com/packages).)

MAX3737

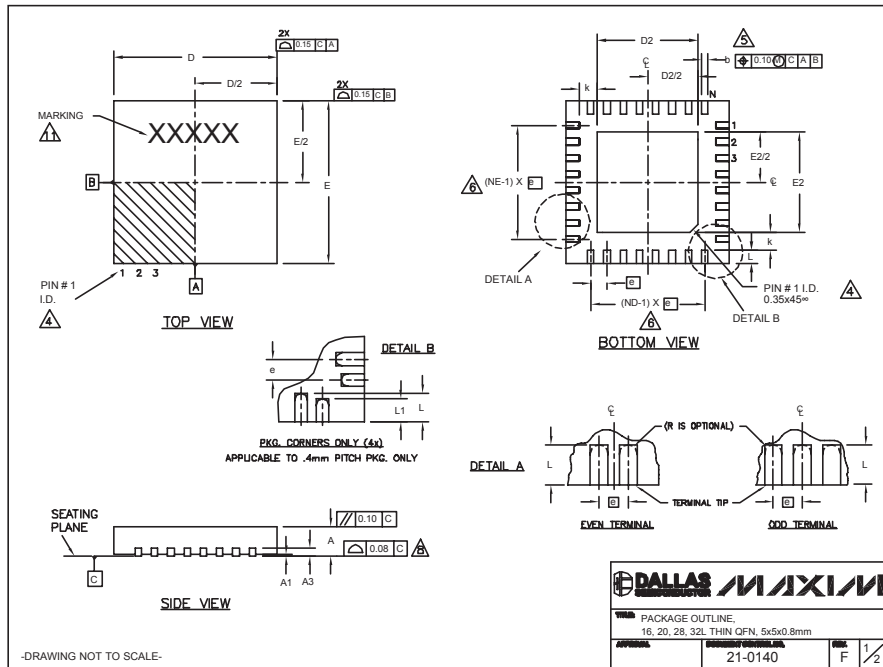

COMMON DIMENSIONS												
PKG.	16L 5x5			20L 5x5			28L 5x5			32L 5x5		
SYMBOL	MIN.	NOM.	MAX.	MIN.	NOM.	MAX.	MIN.	NOM.	MAX.	MIN.	NOM.	MAX.
A	0.70	0.75	0.80	0.70	0.75	0.80	0.70	0.75	0.80	0.70	0.75	0.80
A1	0	0.02	0.05	0	0.02	0.05	0	0.02	0.05	0	0.02	0.05
A3	0.20 REF.			0.20 REF.			0.20 REF.			0.20 REF.		
b	0.25	0.30	0.35	0.25	0.30	0.35	0.25	0.30	0.35	0.25	0.30	0.35
D	4.90	5.00	5.10	4.90	5.00	5.10	4.90	5.00	5.10	4.90	5.00	5.10
E	4.90	5.00	5.10	4.90	5.00	5.10	4.90	5.00	5.10	4.90	5.00	5.10
e	0.80 BSC.			0.65 BSC.			0.50 BSC.			0.50 BSC.		
k	0.25	-	-	0.25	-	-	0.25	-	-	0.25	-	-
L	0.30	0.40	0.50	0.45	0.55	0.65	0.45	0.55	0.65	0.30	0.40	0.50
L1	-	-	-	-	-	-	-	-	-	-	-	-
N	16			20			28			32		
ND	4			5			7			8		
NE	4			5			7			8		
JEDEC	WHHB			WHHC			WHHD-1			WHHD-2		

EXPOSED PAD VARIATIONS									
PKG. CODES	D2			E2			L	DOWN BOND ALLOWED	
	MIN.	NOM.	MAX.	MIN.	NOM.	MAX.			
T1655-1	3.00	3.10	3.20	3.00	3.10	3.20	**	NO	
T1655-2	3.00	3.10	3.20	3.00	3.10	3.20	**	YES	
T1655N-1	3.00	3.10	3.20	3.00	3.10	3.20	**	NO	
T2055-2	3.00	3.10	3.20	3.00	3.10	3.20	**	NO	
T2055-3	3.00	3.10	3.20	3.00	3.10	3.20	**	YES	
T2055-4	3.00	3.10	3.20	3.00	3.10	3.20	**	NO	
T2055-5	3.15	3.25	3.35	3.15	3.25	3.35	0.40	Y	
T2855-1	3.15	3.25	3.35	3.15	3.25	3.35	**	NO	
T2855-2	2.60	2.70	2.80	2.60	2.70	2.80	**	NO	
T2855-3	3.15	3.25	3.35	3.15	3.25	3.35	**	YES	
T2855-4	2.60	2.70	2.80	2.60	2.70	2.80	**	YES	
T2855-5	2.60	2.70	2.80	2.60	2.70	2.80	**	NO	
T2855-6	3.15	3.25	3.35	3.15	3.25	3.35	**	NO	
T2855-7	2.60	2.70	2.80	2.60	2.70	2.80	**	YES	
T2855-8	3.15	3.25	3.35	3.15	3.25	3.35	0.40	Y	
T2855N-1	3.15	3.25	3.35	3.15	3.25	3.35	**	N	
T3255-2	3.00	3.10	3.20	3.00	3.10	3.20	**	NO	
T3255-3	3.00	3.10	3.20	3.00	3.10	3.20	**	YES	
T3255-4	3.00	3.10	3.20	3.00	3.10	3.20	**	NO	
T3255N-1	3.00	3.10	3.20	3.00	3.10	3.20	**	NO	

\*\*SEE COMMON DIMENSIONS TABLE

**DALLAS MAXIM**  
 PACKAGE OUTLINE, 16, 20, 28, 32L THIN OFN, 5x5x0.8mm  
 21-0140 F 1/2

-DRAWING NOT TO SCALE-

- NOTES:
1. DIMENSIONING & TOLERANCING CONFORM TO ASME Y14.5M-1994.
  2. ALL DIMENSIONS ARE IN MILLIMETERS. ANGLES ARE IN DEGREES.
  3. N IS THE TOTAL NUMBER OF TERMINALS.
- △ THE TERMINAL #1 IDENTIFIER AND TERMINAL NUMBERING CONVENTION SHALL CONFORM TO JEDEC 95-1 SPP-012. DETAILS OF TERMINAL #1 IDENTIFIER ARE OPTIONAL, BUT MUST BE LOCATED WITHIN THE ZONE INDICATED. THE TERMINAL #1 IDENTIFIER MAY BE EITHER A MOLD OR MARKED FEATURE.
- △ DIMENSION b APPLIES TO METALLIZED TERMINAL AND IS MEASURED BETWEEN 0.25 mm AND 0.30 mm FROM TERMINAL TIP.
- △ ND AND NE REFER TO THE NUMBER OF TERMINALS ON EACH D AND E SIDE RESPECTIVELY.
7. DEPOPULATION IS POSSIBLE IN A SYMMETRICAL FASHION.
- △ COPLANARITY APPLIES TO THE EXPOSED HEAT SINK SLUG AS WELL AS THE TERMINALS.
9. DRAWING CONFORMS TO JEDEC MQ220, EXCEPT EXPOSED PAD DIMENSION FOR T2855-1, T2855-3 AND T2855-6.
10. WARPAGE SHALL NOT EXCEED 0.10 mm.
- △ MARKING IS FOR PACKAGE ORIENTATION REFERENCE ONLY.
12. NUMBER OF LEADS SHOWN ARE FOR REFERENCE ONLY.

Maxim cannot assume responsibility for use of any circuitry other than circuitry entirely embodied in a Maxim product. No circuit patent licenses are implied. Maxim reserves the right to change the circuitry and specifications without notice at any time.

Maxim Integrated Products, 120 San Gabriel Drive, Sunnyvale, CA 94086 408-737-7600 17